

USER'S GUIDE



MAYTAG

INTRODUCTION..... Page 1

SAFETY..... Page 2

CONTROLS..... Pages 3-5

OPERATING TIPS..... Pages 5-6

LAUNDRY TIPS..... Pages 6-7

MOVING AND STORAGE..... Page 8

BEFORE YOU CALL..... Pages 9-10

WARRANTY..... Page 11

NOTE: In our continuing effort to improve the quality of our appliances, it may be necessary to make changes to the appliance without revising this guide.

IMPORTANT: Keep this guide and the sales receipt in a safe place for future reference. Proof of original purchase date is needed for warranty service.

IMPORTANT: For service and warranty information, see page 11.

THANK YOU FOR BUYING A MAYTAG WASHER!

Please take the time to complete the registration card and return promptly. If registration card is missing, call Maytag Customer Assistance. When contacting Maytag, provide product information from serial plate found on lower right-hand corner of inner lid:

Model Number _____

Serial Number (S/N) _____

Purchase Date _____

Dealer Name _____

Dealer Address _____

Dealer Phone _____

Keep this manual and your sales receipt together in a safe place for future reference or if warranty service is required.

For additional questions, please contact us: Maytag Appliances Sales Company, 1-800-688-9900 USA, 1-800-688-2002 Canada, 1-800-688-2080 USA TTY (for deaf, hearing impaired or speech impaired) Mon.-Fri., 8am-8pm Eastern Time; Internet: <http://www.maytag.com>. Warranty service must be performed by an authorized servicer. Maytag Appliances also recommends contacting an authorized servicer if service is required after warranty expires.

For more information on this and other Maytag products, visit our Web site

www.maytag.com

or

call Maytag Customer Assistance at

1-800-688-9900 (U.S.A.)

1-800-688-2002 (Canada)

1-800-688-2080 (TTY U.S.A. Only)

PARTS AND ACCESSORIES

Purchase replacement parts and additional accessories by phone. To order accessories for your Maytag product, call 1-800-688-9900 inside U.S.A., 1-800-688-2080 for U.S. customers using TTY for deaf, hearing impaired or speech impaired or 1-800-688-2002 for Canada.

SAVE TIME AND MONEY

If something seems unusual, please check "Before you Call" section, which is designed to help you solve problems before calling service. If you have a question, write or call us (include model number and phone number) at:

Maytag Appliances Sales Company

Attn: CAIR® Center

P.O. Box 2370

Cleveland, TN 37320-2370

U.S. 1-800-688-9900

Canada 1-800-688-2002

U.S. customers using TTY for deaf, hearing impaired or speech impaired, call 1-800-688-2080.

WHAT YOU NEED TO KNOW ABOUT SAFETY INSTRUCTIONS

Warning and Important Safety Instructions appearing in this manual are not meant to cover all possible conditions and situations that may occur. Common sense, caution, and care must be exercised when installing, maintaining, or operating the appliance.

Always contact your dealer, distributor, service agent, or manufacturer about problems or conditions you do not understand.

RECOGNIZE SAFETY SYMBOLS, WORDS, LABELS

 **DANGER**

DANGER – Immediate hazards which **WILL** result in severe personal injury or death.

 **WARNING**

WARNING – Hazards or unsafe practices which **COULD** result in severe personal injury or death.

 **CAUTION**

CAUTION – Hazards or unsafe practices which **COULD** result in minor personal injury or product or property damage.

IMPORTANT SAFETY INSTRUCTIONS

WARNING:

To reduce risk of fire, electric shock, serious injury, or death when using your washer, follow basic precautions, including the following:

1. Read all instructions before using washer.
2. Be sure washer is properly grounded.
3. Do not wash articles that have been cleaned in, washed in, soaked in, or spotted with gasoline, dry-cleaning solvents, or other flammable or explosive substances. Vapors could ignite or explode.
4. Do not add gasoline, dry-cleaning solvents, or other flammable or explosive substances to wash water. Vapors could ignite or explode.
5. Do not store or use gasoline or other flammable vapors and liquids near this or any other appliance.
6. Do not allow children or pets to play on, in, or in front of the appliance. Close supervision is necessary when the appliance is used near children and pets.
7. Before washer is removed from service or discarded, remove door to washing compartment.
8. Do not reach into washer if wash tub is moving or agitator is moving.
9. Do not install or store washer where it will be exposed to water and/or weather.
10. Do not tamper with washer controls.
11. Do not repair or replace any part of washer or attempt any service, unless specifically recommended in user-maintenance instructions or in published user-repair instructions that you understand and have skills to carry out.
12. To reduce risk of electric shock or fire, do not use extension cords or adapters to connect washer to electrical power source.
13. Use your washer only for its intended purpose: non-commercial clothes washing.
14. Always disconnect washer from electrical supply before attempting any service. Disconnect power cord by grasping the plug, not the cord.
15. Install washer according to Installation Instructions. All connections for water, drain, electrical power, and grounding must comply with local codes and be made by licensed personnel when required.
16. To reduce risk of fire, do not use washer to launder clothes which have traces of any flammable substance, such as vegetable oil, cooking oil, machine oil, flammable chemicals, thinner, etc., or anything containing wax or chemicals, such as mops and cleaning cloths. Flammable substances may cause fabric to catch fire by itself.
17. Use only fabric softeners or products to eliminate static that are appropriate for automatic washers.
18. Keep your washer in good condition. Bumping or dropping washer can damage safety features. If damage occurs, have washer checked by qualified service technician.
19. Replace worn power cords and/or loose plugs.
20. Loading door must be closed whenever washer is agitating or spinning. Do not bypass loading door switch by permitting washer to operate with loading door open.
21. Always read and follow manufacturer's instructions on packages of laundry and cleaning aids. Heed all warnings or precautions. To reduce risk of poisoning or chemical burns, keep products away from children at all times, preferably, in a locked cabinet.
22. Never operate washer with guards and/or panels removed.
23. Do not operate washer with missing or broken parts.
24. Do not bypass safety devices.
25. Under certain conditions, hydrogen gas may be produced in a hot water system that has not been used for 2 weeks or more. HYDROGEN GAS IS EXPLOSIVE. If the hot water system has not been used before using a washing machine, turn on all hot water faucets and let the water flow from each for several minutes. This will release any accumulated hydrogen gas. As the gas is flammable, do not smoke or use an open flame during this time.

CAUTION:

To reduce risk of property damage due to flooding of washer unit, follow basic precautions, including the following:

1. Do not pause an active cycle for longer than thirty minutes. Pressure switch may reset and cause tub to overflow.
2. Always turn Water Level knob to RESET before changing a water level.
3. DO NOT hold Water Level knob at RESET. Water will continue to fill as long as knob is held at RESET.

SAVE THESE INSTRUCTIONS FOR FUTURE REFERENCE

CONTROLS AT A GLANCE

STEP 1 SELECT WASH/RINSE TEMPERATURE

Always follow garment manufacturer's care labels for each fabric. See chart to the right.

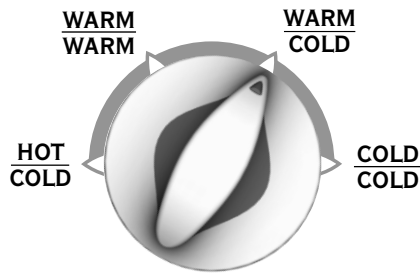

WASH/RINSE TEMP

LOAD TYPE

HOT/COLD: Sturdy whites and colorfast items; work clothes, soiled items, and cloth diapers.

WARM/WARM: Delicate or colorfast items.

WARM/COLD: Moderately soiled permanent press, silks, woolens, nylon, acrylic, rinsing of some items.

COLD/COLD: Non-colorfast items, extra-delicate clothing; rinsing of most items.

STEP 2 SELECT WATER LEVEL

Variable control allows you to select the most appropriate setting for each wash load. Do not fill above top row of holes in tub with clothes. Use Water Level chart to the right to determine setting.

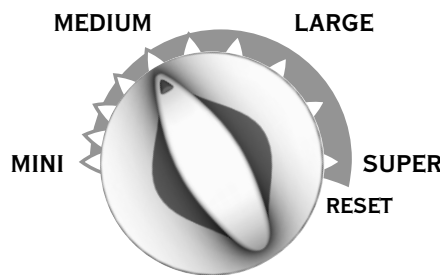

WATER LEVEL

If the tub is filling and you decide to change the WATER LEVEL setting, you must turn the knob to RESET before changing the load size. The tub can overflow if you do not turn to RESET first.

IMPORTANT: Do not pause cycle for longer than 30 minutes. Internal pressure switch may reset and cause tub to overflow. If cycle has been paused for more than 30 minutes, set your Cycle Dial to spin and set your wash cycle again.

IMPORTANT: Do not hold knob at RESET for extended periods or washer flooding may result.

WATER LEVEL

MINI:	1/2 Full
MEDIUM:	1/2 – 3/4 Full
LARGE:	3/4 – Full
SUPER:	Max. Fill

STEP 3 SELECT WASH/SPIN SPEED

Select wash/spin speed most appropriate to type of fabric in wash load. See chart to the right.

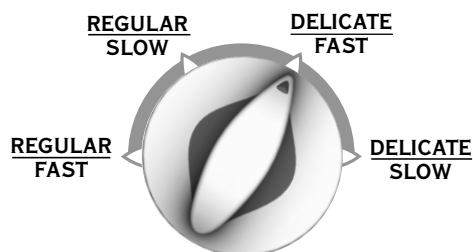

WASH/SPIN SPEED

LOAD TYPE

REGULAR/FAST: Sturdy fabrics needing maximum water extraction.

REGULAR/SLOW: Sturdy fabrics needing slower spin speed to reduce wrinkling.

DELICATE/FAST: Heavy loads of delicate fabrics needing fast spin for better water extraction.

DELICATE/SLOW: Delicate fabrics needing slower spin to protect fabric and clothing.

STEP 4 SELECT WASH CYCLE

Push timer knob in and turn to desired cycle and wash time. Timer knob can be turned in either direction. Wash cycle selection depends upon type of fabric and amount of soil. For best results when cleaning heavily soiled items, use the HEAVY setting. Lightly soiled items require less wash time. See below for more information.

SOAK

Use for heavily soiled or stained items. Washtub fills with water, pauses approximately 12 minutes for soaking, and spins water out to complete cycle.

HAND WASH

Use for fine fabrics normally washed by hand. To protect fragile fabrics, washer speed automatically runs at Delicate/Slow, regardless of position of speed selector switch.

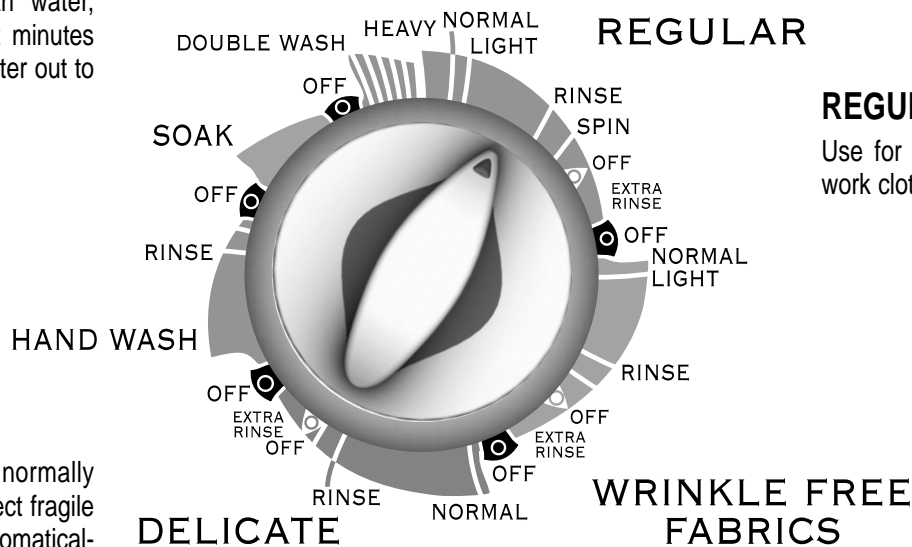

DELICATE

Use to wash delicate items often washed by hand. Even with small loads, full tub of water is recommended so items can move freely for more complete cleaning. More water also helps reduce fabric wear and wrinkling. To protect delicate fabrics, washer speed automatically runs at Delicate/Slow, regardless of position of speed selector switch.

WRINKLE FREE FABRICS

Use for clothes that recommend a permanent press cycle and other synthetics.

Pull OUT timer knob to start.

Water fill begins. Stop washer by pushing knob in.

DOUBLE WASH

DOUBLE WASH automatically advances into the REGULAR wash cycle. Use to wash heavily soiled clothes twice with detergent in each cycle.

To deliver extra detergent:

- LIQUID DETERGENT: Place in fabric softener dispenser for use in second wash. *DO NOT* use dispenser for fabric softener.
- POWDER DETERGENT: Place extra detergent in tub for use in first wash; recommend approximately 1 1/2 times normal amount.

REGULAR

Use for sturdy items, like play or work clothes, towels, T-shirts, etc.

CONTROLS AT A GLANCE CONT.

STEP 5 SELECT 'EXTRA RINSE', IF DESIRED

EXTRA RINSE is useful for people with detergent sensitive skin. It provides a second rinse to more completely remove laundry additives, suds, and perfumes in **REGULAR**, **WRINKLE FREE FABRICS**, and **DELICATE** cycles. To select, set switch to **ON**. Set switch to **OFF** if not desired. **EXTRA RINSE** adds 10–15 minutes to total cycle time.

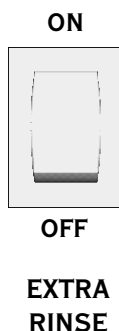

OPERATING TIPS

BLEACH DISPENSER

Bleach dispenser is located in left front corner under loading door.

Use only liquid bleach in dispenser. To use powdered bleach, add to wash tub with detergent.

Carefully pour recommended amount of bleach into dispenser during first washer fill. See table.

Be careful not to spill undiluted bleach. It is a strong chemical and can damage cabinet finishes and some fabrics if not properly diluted. Follow bleach manufacturer's label for proper use.

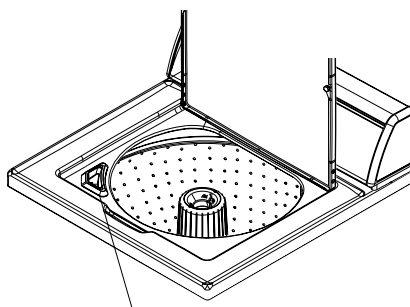

LOAD SIZE	BLEACH (max. amt.)
SUPER:	1 cup
LARGE:	1 cup
MEDIUM:	3/4 cup
SMALL:	1/2 cup

LOADING

MEASURE AND ADD DETERGENT TO WASHTUB

Use only detergent recommended for top-loading washers.

ADD CLOTHING TO WATER IN WASHTUB

- Clothes should fill wash tub but should not be packed. Loosely fill tub with clothes no higher than top row of holes. Items must move freely through wash/rinse water.
- Bulky fabrics may need more water added after agitation begins. Turn Water Level knob to **RESET** and back to desired setting.

CLOSE WASHER LID

Washer will not operate when lid is open.

FABRIC SOFTENER DISPENSER

Fabric softener dispenser is located on top of agitator. Dispenser automatically releases liquid fabric softener at proper time during rinse cycle.

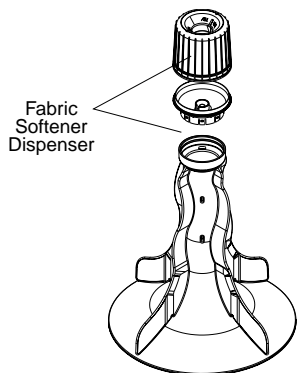

FABRIC SOFTENER TIPS

- Liquid fabric softeners are dispensed during final rinse. Do not combine with bleach, bluing, starch, detergents, soaps, or packaged water conditioners during rinse.

- Do not use fabric softener in dispenser during DOUBLE WASH cycle.
- Do not mix powdered detergent with liquid softener in dispenser or softener will become gummy.

To use dispenser, follow these steps:

1. Pour liquid fabric softener into dispenser, using amount recommended on package.
2. Add water up to fill level, but do not exceed tip of fill arrow indicator. **FABRIC SOFTENER MUST BE DILUTED FOR USE.**
 - Do not stop washer during first spin or dispenser will empty too soon.
 - Never pour fabric softener directly onto clothes or spots and stains may result. To remove softener stains, soak in soapy solution of Sard™ Wonder Soap or Ivory™ soap, or rub stain with bar of Sard™ or Ivory™ soap and wash garment as usual.

- For best softener performance, set water level to medium or higher.

3. **Clean softener dispenser after each use.** Remove dispenser housing from agitator by squeezing lower part of dispenser and pulling up on housing while tilting slightly to expose dispenser cup. Rinse dispenser housing and cup in hot soapy water.

Clean funnel shape in top of agitator and inside of agitator. Use small brush on hole and slots in two funnel rings for thorough cleaning.

After cleaning, reinstall dispenser cup. Push dispenser housing directly down onto top of agitator until firmly snapped together.

To prevent buildup, fill dispenser with clean water in wash cycles when not using softener.

SPECIAL LAUNDRY TIPS

NEED MORE TIME? RESET THE TIMER KNOB.

Although wash cycles are automatic, timer may be reset to lengthen, shorten, or repeat a portion of a cycle.

To set or reset timer, push in timer knob to stop washer. Hold in timer knob firmly while slowly turning it to desired setting. Pull out timer knob to start washer.

STOPS AND STARTS

Wash action consists of periods of agitation, with pauses or periods of soaking. For best results, do not turn timer through pauses, which are normal part of wash cycles.

CLEANER CLOTHES

Water temperature affects how clean clothes become. If your clothes are not as clean as you would like, check your water heater temperature. Check your water heater manufacturer's recommendations, as well as local codes, for assistance. Also, check that your water hoses are hooked up correctly. If they are switched you might be getting cold water in your warm and hot cycles.

Hard water does not remove soil as well as soft water. Check with your local water company to see if you have hard water. If you have hard water, try softening it with a packaged conditioner or use a little more detergent.

RISERS

Risers or air cushions may be installed if pipes knock or pound when flow of water stops. Risers are more efficient when installed as close as possible to water supply faucets.

SPECIAL LAUNDRY TIPS CONT.

LINT FILTER

Maytag's self cleaning lint filter works throughout the wash cycle to constantly remove lint and other residue from the water. Located between the outer and inner tub, the lint filter removes lint as water passes from the bottom of the outer tub back to the inner tub. As water passes from the outer tub to the inner tub, water is forced through the bottom of the lint filter. The filter traps lint under the filter until the spin cycle begins. During the spin cycle centrifugal force removes the lint by pulling it off the bottom of the filter and washing it down the drain.

MOTOR OVERLOAD PROTECTOR

Internal overload protector automatically stops motor in event of overload. Overload protector resets in approximately 3 minutes and motor automatically restarts. If overload protector stops motor again, stop using washer and call service technician. Loading wash tub too full may result in motor overload.

AUTOMATIC BALANCE SYSTEM

Your new washer will automatically adjust to unbalanced loads without shutting down or interrupting the cycle. The cycle will automatically complete at the fastest spin speed possible.

In a severe out-of-balance condition, clothes may contain excessive moisture. If this should happen, simply redistribute the clothes, and reset the control to the spin mark after the rinse setting in the regular cycle.

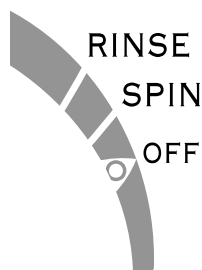

SAFETY LID SWITCH

The washer will not spin when the lid is open for any reason. This is for your personal safety. If the lid is opened mid-cycle, operation will automatically start when lid is closed.

GENERAL WASHER CARE

- Use only damp or sudsy cloth for cleaning control panel. Some cleaning product sprays may harm control panel finish or may damage interior of hood.
- Wipe washer cabinet as needed. If detergent, bleach, or other washing products are spilled on cabinet, wipe immediately. Some products will cause permanent damage if spilled on cabinet.
- Top of washer should not be used for removing garment stains. Some stain removers, such as rust remover, may damage cabinet finish.
- Do not use scouring pads or abrasive cleansers.
- Do not lay sharp or rough objects on or against washer. Finish could be damaged.
- Remove pins, buckles, or other sharp objects from clothes to prevent scratching interior parts.
- Leave lid open after use to allow inside of washer to dry, and to help prevent musty odors from developing.
- Do not allow small children to play on or around washer.
- Do not move washer without reinstalling shipping brace and shipping plug. See *Moving Washer to New Location* section.

MOVING AND STORAGE

⚠ WARNING:

Explosive hydrogen gas may be produced in a hot water system that has not been used for two weeks or more. Before using washer, if hot water system has not been used for such a period, turn on all hot water faucets and let water flow for several minutes to release accumulated hydrogen gas. Hydrogen gas is flammable: Do not smoke or use an open flame when flushing water lines.

COLD STORAGE AND NON-USE PERIODS

COLD WEATHER CARE

If washer is delivered when outside temperature is below freezing or if washer is stored in unheated room or area during cold months, **do not operate until washer has warmed to room temperature. Do not install or operate washer where temperatures will drop below freezing.**

COLD WEATHER STORAGE

If washer must be stored in seasonal home or storage building, use one of the following storage methods.

METHOD 1

1. Turn off water supply faucets and disconnect hoses. Drain water from both hoses.
2. Add one gallon of *non-toxic RV antifreeze* (available from hardware or recreational vehicle dealers) to washer tub.
3. Push in cycle selector knob and turn to SPIN.
4. Pull knob out and let washer spin for 1–2 minutes to drain water. Some antifreeze will also be lost. (If you have a septic system, contact antifreeze manufacturer and make sure it will not harm system.)
5. Push in cycle selector knob to stop washer. Dry inner wash tub, disconnect electrical plug, and close washer lid. If moving washer, disconnect drain hose. Move and store washer

ONLY in upright position. To remove antifreeze after storage, run washer through a complete cycle using 1/2 cup of detergent. **DO NOT ADD CLOTHES TO CYCLE.**

METHOD 2

1. Push in cycle selector knob and turn to SPIN. Run through complete spin cycle to remove excess water.
2. When spin cycle is complete, push in cycle selector knob to stop washer.
3. Turn off water supply faucets and disconnect hoses. Drain water from both hoses.
4. Dry inner wash tub, disconnect electrical plug, and close washer lid. If moving washer, disconnect drain hose. Move and store washer ONLY in upright position.
5. It is normal for some water to remain inside pump. To prevent damage to washer and pump if remaining water freezes, allow washer to warm 24 to 48 hours after removing from storage, so water can thaw before use.

VACATIONS AND EXTENDED NON-USE

IMPORTANT: To avoid possible property damage from flooding, turn off water supply to washer during extended periods of non-use.

To prevent mold or mildew, leave lid open so moisture inside machine can evaporate.

When closing your home for extended periods, have service technician drain washer to avoid stagnant water. Unplug cord from electrical outlet. Disconnect hoses from faucets.

MOVING WASHER TO NEW LOCATION

Replace shipping plug under motor and shipping brace in tub. Refer to *Installation Instructions* for proper procedures whenever washer is moved. See illustration.

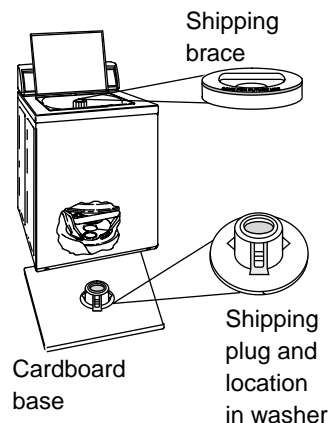

Tilt washer back slightly and slide shipping plug into position under washer.

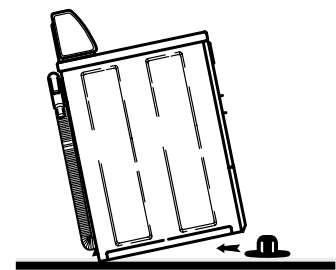

BEFORE YOU CALL

You may save time and money by checking items below before calling for service. List includes common concerns that are not the result of defective workmanship or materials.

TOPIC	POSSIBLE CAUSE	SOLUTION
NOISE		
Gear Sounds or a Low Hum	Normal mechanical sounds in commercial-quality washer.	Normal operation.
Rattling and Clanking Noise	Loose objects, such as coins or pins, in tub or pump.	Stop washer and check tub. Remove loose objects. If noise continues after washer is restarted, objects may be in pump: call your authorized servicer.
	Belt buckles, metal fasteners hitting wash tub.	Close zippers, buttons, and fasteners. Clothing with buckles must be turned inside out.
Squealing Sound or Hot Rubber Odor	Overloaded wash tub.	Do not overload washer. Stop washer and reduce size of load.
Thumping Sound	Heavy wash loads; unbalanced loads.	Usually normal, but unbalanced loads should be redistributed. Stop washer and rearrange load.
Vibrating Noise	Washer not resting firmly on floor.	Make sure floor is strong enough for washer. Adjust leveling legs so washer rests firmly on floor. See <i>Installation Instructions</i> for leveling details.
	Wash load distributed unevenly in tub.	Stop washer and rearrange load.
	Shipping plug not removed during installation.	See <i>Installation Instructions</i> for details on removing shipping plug.
Water Splashing or Slapping Noise	Spray rinse.	Normal operation. Washer sprays water inside tub while running at high speed during rinse and spin.
Whistling or Whirling Noise	Drum spinning without clothes.	Normal operation. Holes in the tub can cause this sound.
OPERATION		
Washer Does Not Start	Electrical power cord may not be plugged in, or connection may be loose.	Make sure plug from power cord fits tightly into wall outlet.
	Fuse blown, circuit breaker tripped, or power outage occurred.	Replace fuse or reset circuit breaker. Do NOT increase fuse capacity. Call qualified electrician to correct circuit overload problem. Call local utility company to correct power outage.
	Water supply faucets not turned on.	Turn on water supply faucets.
	Timer knob/cycle selector set incorrectly.	Move indicator slightly clockwise. Pull out on timer knob.
	Motor overheated.	Internal overload protector automatically stops motor in event of overload. Protector resets in approximately 3 minutes and motor automatically restarts. If overload protector stops motor again, quit using washer and call service technician. Do not overload washer. Largest dry load level should not be higher than bottom of fabric softener dispenser or top of agitator.
Washer Won't Spin	Lid partially open.	Close lid completely.
Residue Left in Tub	Heavily soiled items.	Wipe tub with non-abrasive household cleaner and rinse. Before washing, shake or brush excess dirt and sand from items.

TOPIC	POSSIBLE CAUSE	SOLUTION
WATER		
Wash Load Too Wet After Spin	Overloaded wash tub.	Do not overload washer.
	Unbalanced load.	Rearrange load to allow proper spin.
	Kinked drain hose.	Straighten drain hose.
Water Enters Slowly or Does Not Enter Washer	Inadequate main water supply.	Check water pressure at another faucet in house. Wait for water supply and pressure to increase.
	Water supply faucets partly closed.	Fully open hot and cold water supply faucets.
	Water being used elsewhere in house.	Water pressure must be at least 20 psi (138 kPa). Avoid running water elsewhere when washer is filling.
	Clogged water inlet filters.	Disconnect water fill hoses from faucet. Clean and reposition screen filters. Reconnect water fill hoses.
	Kinked water inlet hoses.	Straighten hoses.
Water Level Does Not Cover Clothes	Incorrect water level selection.	Select higher water level. Add water by turning selector to RESET and back to larger load size.
	Overloaded wash tub.	Do not overload washer. Largest dry load level should not be higher than bottom of fabric softener dispenser or top of agitator.
Warm or Hot Water Not Hot Enough	Water heater temperature set too low; water heater too far from washer.	You may need to raise the temperature on your water heater. Check your water heater manufacturer's recommendations, as well as local codes for assistance.
	Hot water being used elsewhere in house.	Avoid using hot water elsewhere before or during washer use, or there may not be enough hot water for proper cleaning. If problem continues, enlarge capacity of hot water system, or use for only one application at a time.
Water Drains Slowly or Does Not Drain	Drain hose kinked or clogged.	Clean and straighten drain hose.
Water Leaks	Loose fill hose connections.	Check and tighten all hose/faucet connections. Install rubber sealing washers provided.
	Clogged drain pipes.	Unclog drain pipes. Call plumber if necessary.
	Changed water levels during fill.	Always use RESET on water level switch when changing water level. Do not hold switch at RESET; return switch to desired load size.
	Oversudsing.	Use less detergent.
Incorrect Wash and Rinse Temperatures	Hot and cold water hoses connected to wrong supply faucets.	Check hose connections. Connect hot water hose to hot water faucet; connect cold water hose to cold water faucet.
Water Enters Washer, but Tub Does Not Fill	Incorrect standpipe height for drain hose.	Recommended standpipe height is 36" (91.44 cm); for low standpipes, install Siphon Break Kit. See <i>Installation Instructions</i> for details.

MAYTAG WASHER WARRANTY

Full One Year Warranty

For one (1) year from the date of original retail purchase, any part which fails in normal home use will be repaired or replaced free of charge.

Limited Warranty

After the first year from date of original retail purchase, through the time periods listed below, the parts designated below which fail in normal home use will be repaired or replaced free of charge for the part itself, with the owner paying all other costs, including labor, mileage and transportation.

Second Year – All parts.

Third through Fifth Year – The drive motor. All parts of the solid state controls (if so equipped).

Third through Tenth Year – All parts of the transmission assembly.

Third through Lifetime – The inner wash basket.

Additional Limited Warranty Against Rust-Through

Should an exterior cabinet, including the top, lid and baseframe, rust through during the one year period starting from the date of retail purchase, repair or replacement will be made free of charge. After the first and through the tenth year, repair or replacement will be made free of charge for the part itself, with the owner paying all other costs, including labor, mileage and transportation.

Please Note: This full warranty and the limited warranty apply when the washer is located in the United States or Canada. Washers located elsewhere are covered by the limited warranty only, including parts which fail during the first two years.

Canadian Residents

This warranty covers only those appliances installed in Canada that have been listed with the Canadian Standards Association unless the appliances are brought into Canada due to transfer of residence from the United States to Canada.

The specific warranties expressed above are the ONLY warranties provided by the manufacturer. This warranty gives you specific legal rights, and you may also have other rights that vary from state to state.

TO RECEIVE WARRANTY SERVICE

Service must be performed by an authorized Maytag service representative. To schedule service, contact the Maytag dealer where you purchased your appliance or contact :

Maytag Appliances Sales Company
Attn: CAIR® Center
P.O. Box 2370
Cleveland, TN 37320-2370

U.S. 1-800-688-9900

Canada 1-800-688-2002

U.S. customers using TTY for deaf, hearing impaired or speech impaired, call 1-800-688-2080.

When contacting Maytag Appliances Sales Company, please include the following information:

- a. Your name, address and telephone number;
- b. Model number and serial number of your appliance;
- c. The name and address of your dealer and the date of purchase;
- d. A clear description of the problem.
- e. Proof of purchase (sales receipt).

WHAT IS NOT COVERED BY THESE WARRANTIES:

1. Conditions and damages resulting from any of the following:
 - a. Improper installation, delivery, or maintenance.
 - b. Any repair, modification, alteration or adjustment not authorized by the manufacturer or an authorized servicer.
 - c. Misuse, abuse, accidents, or unreasonable use.
 - d. Incorrect electric current, voltage or supply.
 - e. Improper setting of any control.
2. Warranties are void if the original serial numbers have been removed, altered, or cannot be readily determined.
3. Products purchased for commercial or industrial use.
4. The cost of service or service call to:
 - a. Correct installation errors.
 - b. Instruct the user on proper use of the product.
 - c. Transport the appliance to the servicer.
5. Consequential or incidental damages sustained by any person as a result of any breach of these warranties.

Some states do not allow the exclusion or limitation of consequential or incidental damages, so the above exclusion may not apply.

User's Guides, service manuals and parts catalogs are available from Maytag Appliances Sales Company, Maytag Customer Assistance.

MAYTAG • 403 W. 4th Street N. • P.O. Box 39 • Newton, Iowa 50208